

Time Switch FM Series

- Modular construction
- Inbuilt over-ride facility
- High switching capacity
- Tamper proof sealing
- Analog & Digital version
- Daily/Weekly programming
- Graphical Program LCD



Ordering Information

Cat. No.	Description	
J648B1	FM/1 QT	240 VAC, Daily Dial, Base / DIN Mounting*
J848B1	FM/1 QW	240 VAC, Weekly Dial, Base / DIN Mounting*
J638B1	FM/1 QT	110 VAC, Daily Dial, Base / DIN Mounting*
J838B1	FM/1 QW	110 VAC, Weekly Dial, Base / DIN Mounting*
D847B2	FM/1 Digi20 Plus	240 VAC, Daily / Weekly, Base / DIN Mounting*

Note: For Flush Mounting model, replace B by F in Cat. No.

Time Switch FM Series



Cat. No.	J648B1	D847B2	
Parameters			
Supply Voltage \oplus	240 VAC		
Frequency	50/60 Hz		
Power Consumption (Max.)	2 VA	4.4 VA	
Accuracy	± 1.5 s/day at 20°C	± 1 s/day at 20°C	
Relay Output	1 C/O	1 C/O	
Contact Rating	Resistive	16A @ 250 VAC, 0.25A @ 220VDC	16A @ 250 VAC
	Inductive ($\cos\phi = 0.6$)	8A @ 250 VAC, 0.1A @ 220 VDC	4A @ 250 VAC
	Incandescent Lamp	1350 W	1350 W
Shortest Switching Time	Daily	15min	1min
	Weekly	2h	1min
Power reserve	150h	10 years from Factory at 20°C	
Memory locations	N. A.	20	
Storage Temperature	- 20°C to + 55°C		
Manual Over-ride	Provided		
Mounting	Flush, Base / DIN rail		
Weight (unpacked)	185 g		

MOUNTING DIMENSION (mm)

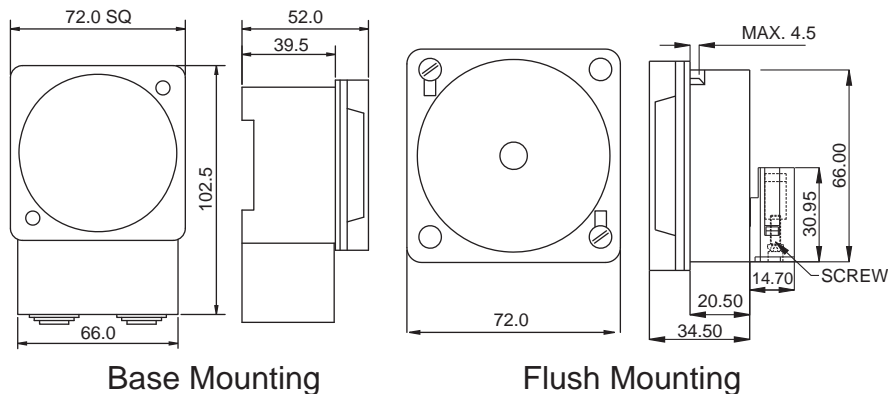

CONNECTION DIAGRAM

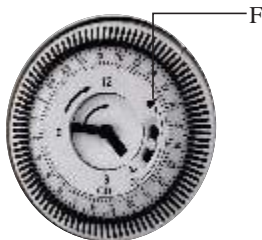
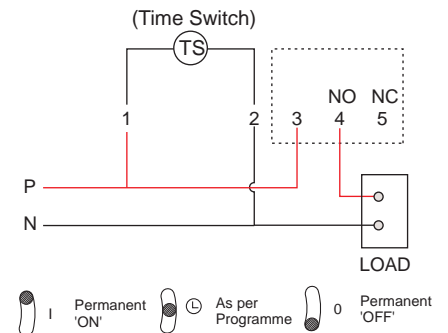



TIME SETTING:

Rotate the switching Dial in clockwise direction until the current time (day / time incase of weekly model) is almost opposite to the marking arrow F. For fine adjustment rotate the minute hand in the clockwise direction until the clock shows the current time.

PROGRAMMING:

Required Switch ON time is set on the Switching Dial by radially pulling outwards the corresponding black segments. Each segment on daily dial corresponds to 15 mins. & on weekly Dial corresponds to 2 hours.

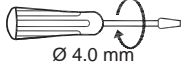
TERMINAL TORQUE & CAPACITY

	Torque - 1.6 N.m (5.3 Lb.in) Terminal screw - M3.5
	Solid Wire - 1 X 0.2...5 mm ²
AWG	1 X 24 to 10

*Products available for sale only in selected Countries